

# PCO2 Next Generation

## Carbon Dioxide Quality Incident Protection Systems for the sparkling beverage industry - production plant



For over 20 years, Parker have delivered robust and reliable CO<sub>2</sub> quality incident protection systems to global bottling sites. Parker has provided peace of mind for our customers and partners. The Next Generation of product range offers new features and design improvements in line with our customer needs.

PCO2 Carbon Dioxide Quality Incident Protection Systems from Parker offer a comprehensive solution to preserve and guarantee the quality of gaseous carbon dioxide used in sparkling beverage bottling.

Using multi-layer adsorbant technology, the PCO2 range is suitable for flow rates between 363 to 4354 Kg/h @ 24 bar g (800 to 9600 Lb/h @ 350 psi g).

Operating as a Quality Incident Protection removing a wide range of potential carbon dioxide impurities, the system guarantees the gas quality so it remains within industry and company guidelines, preventing detrimental consequences to the finished end beverage, producers reputation and their bottom-line.

Approved & recommended by the major global brand leaders, the Parker PCO2 is the beverage industry preferred choice and is installed in over 150 countries worldwide.



### Features:

- Comprehensive six stage technology
- Improved 12-month maximum operational life\*
- Built in safety features
- Simple installation and compact design
- Materials of construction independently verified to comply with FDA Code of Federal Regulations title 21 CFR
- Conforms to global compliance and legislation
- Simplified servicing features

\* 12 -Month operational life dependant on Certified beverage / ISBT grade CO<sub>2</sub> usage and a Mass Flow Meter in situ.

### Benefits:

- Carbon dioxide quality guaranteed. Effective in removing a combination of potential impurities and contaminants.
- Reduced cost of ownership.
- Protection against impurities known to create beverage flavour defects. Helps avoid product spoilage and protects bottlers reputation.
- Ensures carbon dioxide meets industry and company specifications and guidelines. Cleans 'out of specification' gas back within beverage quality guidelines.
- International sales and service support Over 20 years experience.



ENGINEERING YOUR SUCCESS.

## Product Selection

Data is based on 24.1 bar g (350 psi g). For flows at other lower pressures apply the correction factors shown below.

Model	Flow Rate		Quantity Required	Maintenance kit	Number of cartridges
	Kg/h	Lb/h			
PCO2-800	363	800	1	MK-PCO2-800	2
PCO2-1600	726	1600	1	MK-PCO2-1600	4
PCO2-2400	1089	2400	1	MK-PCO2-2400	6
PCO2-3200	1451	3200	1	MK-PCO2-3200	8
PCO2-4000	1814	4000	1	MK-PCO2-4000	10
PCO2-4800	2177	4800	1	MK-PCO2-4800	12
PCO2-3200 Duplex*	2903	6400	2	MK-PCO2-6400	16 (8 per unit)
PCO2-4000 Duplex*	3628	8000	2	MK-PCO2-8000	20 (10 per unit)
PCO2-4800 Duplex*	4354	9600	2	MK-PCO2-9600	24 (12 per unit)

\*Duplex systems are installed in parallel to double the flow  
All systems are rated at a maximum operating pressure of 24.1 Bar g / 350 psi g.

## Pressure Correction Factors

Inlet Pressure	bar g	3	4	5	6	7	8	9	10	11	12	13
	psi g	44	58	73	87	102	116	130	145	160	174	189
Correction factor		0.19	0.23	0.28	0.33	0.38	0.42	0.47	0.52	0.57	0.61	0.66

  

Inlet Pressure	bar g	14	15	16	17	18	19	20	21	22	23	24
	psi g	203	218	232	247	261	275	290	304	319	333	348
Correction factor		0.71	0.76	0.80	0.85	0.90	0.95	1	1	1	1	1

## Weights and Dimensions

Model	Port Size*	Height (H)		Width (W)		Depth (D)		Clearance**		Weight	
		mm	ins	mm	ins	mm	ins	mm	ins	kg	lbs
PCO2-800	1 1/2"	1060.7	41.8	632	24.9	450	17.7	680	27	84	185
PCO2-1600	1 1/2"	1060.7	41.8	801	31.5	450	17.7	680	27	128	282
PCO2-2400	1 1/2"	1060.7	41.8	970	39.4	450	17.7	680	27	172	379
PCO2-3200	1 1/2"	1060.7	41.8	1139	44.8	450	17.7	680	27	217	478
PCO2-4000	1 1/2"	1060.7	41.8	1308	51.5	450	17.7	680	27	260	573
PCO2-4800	1 1/2"	1060.7	41.8	1477	58.1	450	17.7	680	27	304	670

\* All systems are supplied as NPT with stainless steel adapters 'NPT to BSP' as standard.  
\*\* Clearance required for the removal and servicing of cartridges

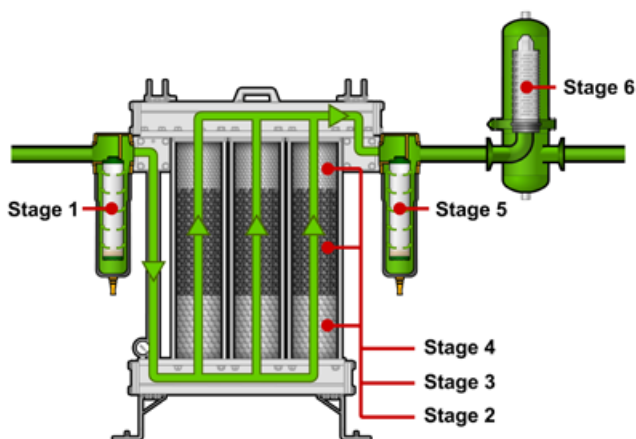
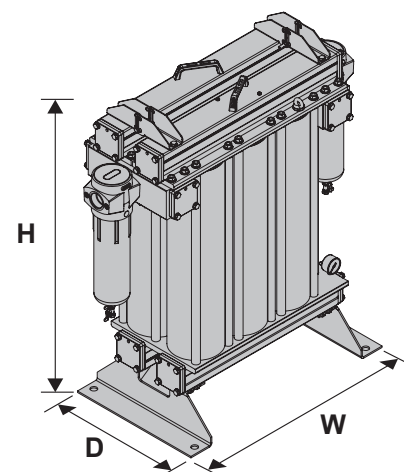

- Stage 1**  
0.01 micron particle filtration  
Removal of non-volatile organic residue (NVOR) and other contaminants down to 0.01 ppm
- Stage 2**  
Removal of water vapour and partial removal of hydrocarbons
- Stage 3**  
Primary removal of aromatic hydrocarbons (Benzene, Toluene etc and Acetaldehyde)
- Stage 4**  
Removal of sulphur compounds (COS, H2S, DMS etc)
- Stage 5**  
0.01 micron particle filtration
- Stage 6\***  
Point of use VBACE sterile gas membrane. Hi Flow Tetpor II

\* Optional - Sterilizing Grade: consult Parker for operational use

### EMEA Product Information Centre

Free phone: 00 800 27 27 5374

(from AT, BE, CH, CZ, DE, DK, EE, ES, FI, FR, IE, IL, IS, IT, LU, MT, NL, NO, PL, PT, RU, SE, SK, UK, ZA)

### US Product Information Centre

Toll-free number: 1-800-27 27 537

www.parker.com/gsf

